

crazy about

hexalobe

THE NEW MACHINING
CONCEPT

NEW



crazy about new concept



THE NEW CONCEPT FOR MACHINING YOUR TORX® SOCKET

New concept

- Drilling - Chamfering - Milling - Deburring: Four operations in three steps with two tools.
- High efficient machining in shorter time for titanium, stainless steel and cobalt chrome.

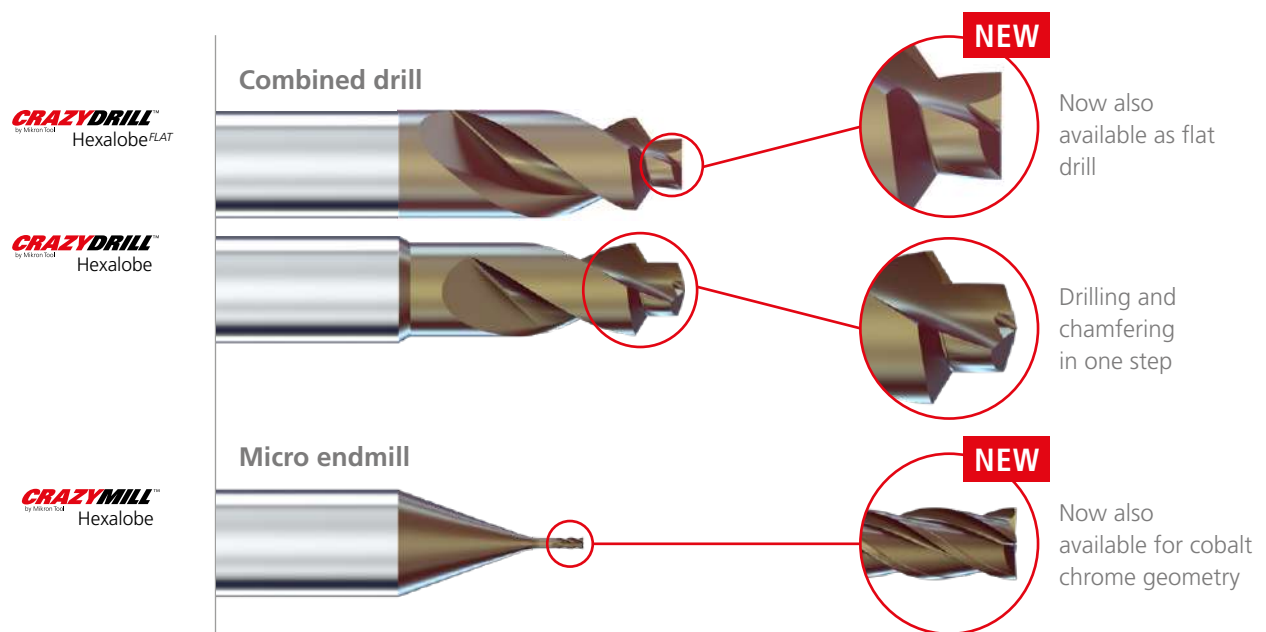

Performance features

- Highest stiffness
- New cutting geometry



Your advantages

- Shorter milling process
- Highest profile precision
- Excellent surface quality
- Minimal burr

Regrinding: These products are not suitable for regrinding.

Please note: You couldn't find your suitable version of the CrazyDrill Hexalobe / CrazyMill Hexalobe (diameter, length, cutting direction...)? Ask us about our customized versions!

NEW

Best performance on hexalobular sockets

TURNKEY SOLUTION FOR TITANIUM, STAINLESS STEEL AND COBALT CHROME



Material

■ Titanium

S2

Ti Gr.5 ELI
TiAl6V4 ELI
3.7165

■ Stainless Steel

M

316 LM
X2CrNiMo18-15-3
1.4441

■ Cobalt chrome

S3

ASTM F1537
CrCoMo28
ISO 5832-12

Shape precision

■ Nearly perfect profile

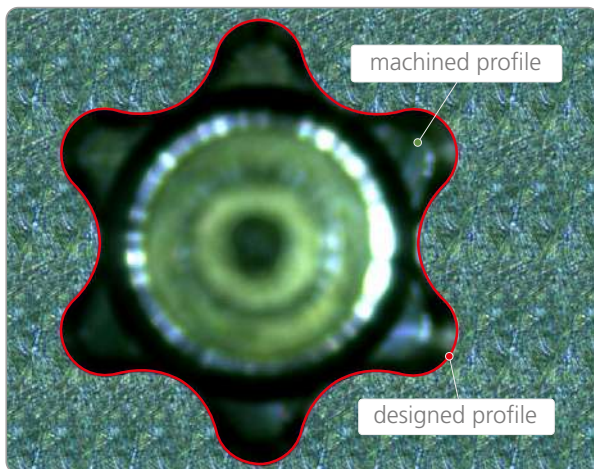

Perfect profile matching.

■ Perpendicularity

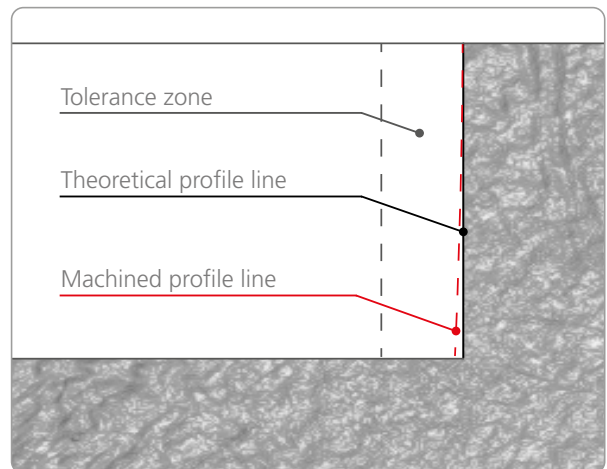

Guaranteed profile geometry.

Quality and performance

■ Surface quality

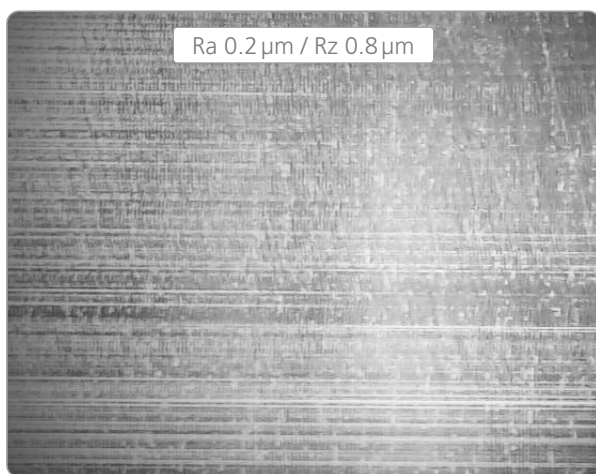

Excellent surface quality.*

■ Nearly burr free

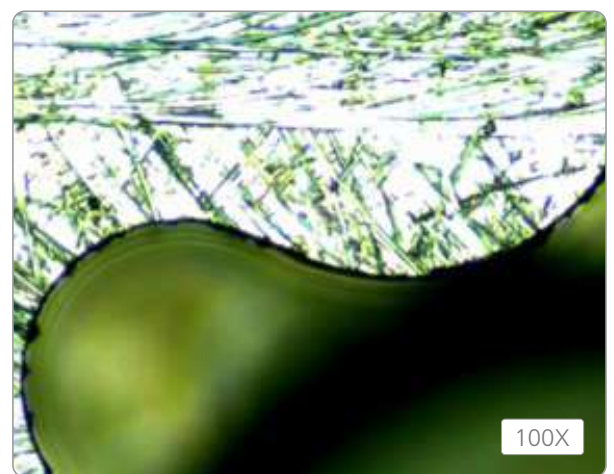

Machining profile with minimal burrs.

■ Chamfer roughness

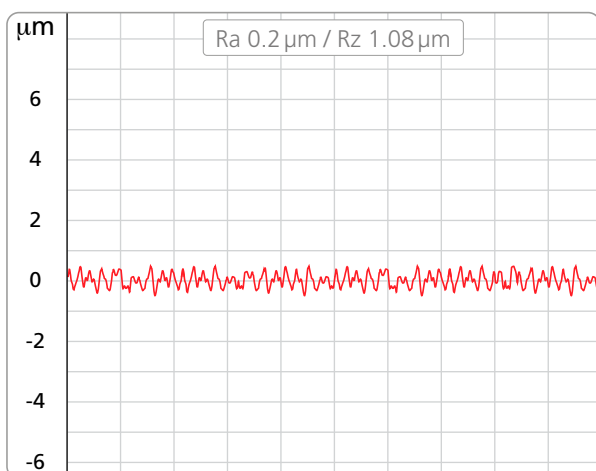

Lowest roughness on chamfer surface.*

■ Milling cycle time

TORX® type	Time [s]
T6	27
T8	24
T10	22
T15	22
T20	21
T25	20

Machined on titanium with version 3.5 x d and p = 0.4 x d.*

Note *: The quality and cycle time depends on cutting parameters and machine conditions.

NEW

High efficient drilling hexalobular socket

CrazyDrill Hexalobe & CrazyDrill Hexalobe Flat

The new combined drill for TORX® socket machining

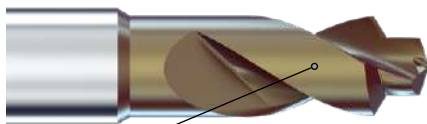

Tip angle of 140°

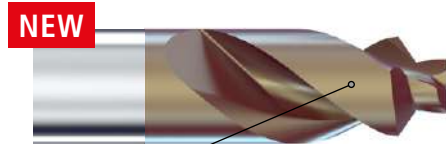

Tip angle of 180°

Features

■ Two in one

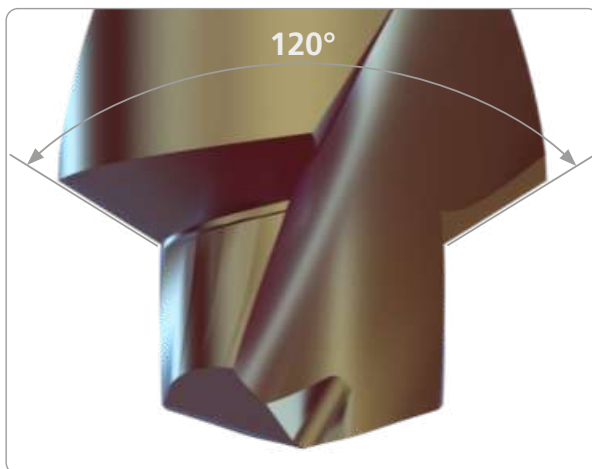

The pre-hole (with tip angle of 140° or 180°) and a 120° chamfer are combined in one single operation.

■ Two cutting geometries

Two types of drills have been developed for best machining titanium, stainless steel and cobalt chrome.

■ Diameter range

Standard diameters for pre-hole drilling "Torx®" socket from T4 to T30.

■ On request

Special sizes available on request.

■ Coating



Chrome free coating to avoid cross contamination on medical parts.

High efficient milling hexalobular socket

NEW

CrazyMill Hexalobe

The new endmill for TORX® socket machining

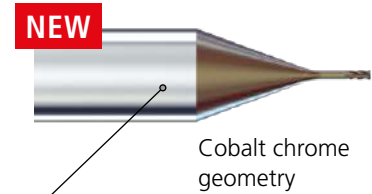
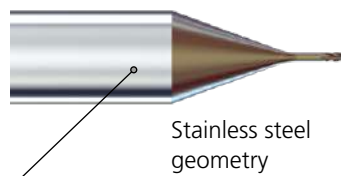
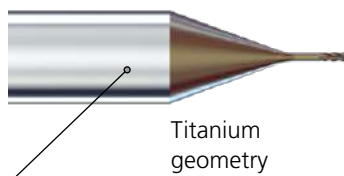

Performance

■ Real cutting conditions

Tested and approved cutting conditions for best process execution and tool life.

■ New carbide

A special micro-grain carbide with high stiffness and edge chipping resistance has been developed to guarantee high profile precision.

■ Helical interpolation

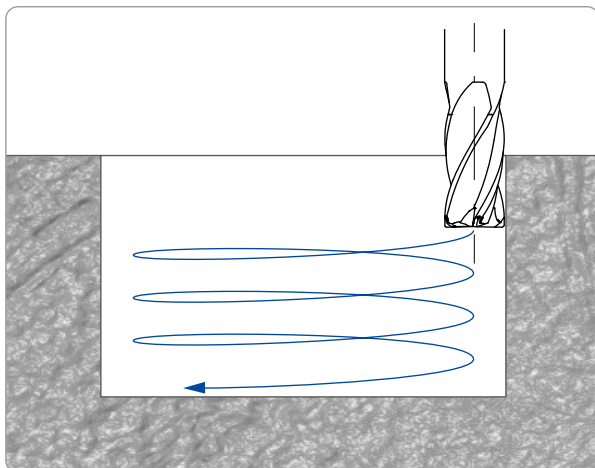

Higher pitch up to $0.8 \times d$.

■ Three cutting geometries

Three types of endmills have been developed for vibration free machining in titanium, stainless steel and cobalt chrome.

■ Coating



Chrome free coating to avoid cross contamination on medical parts.

NEW

Machining process

HELICAL INTERPOLATION FOR TITANIUM

Step 1

Pre-hole drilling with 120° chamfer

Ti
S2

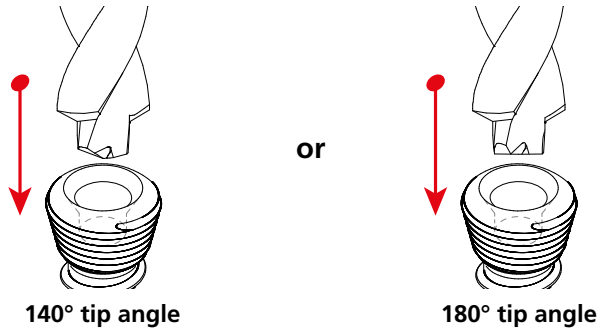

Step 2

Helical interpolation
XYZ

Helical interpolation
XCZ

XYZ
Interpolation of linear axes X, Y and Z with stationary workpiece.

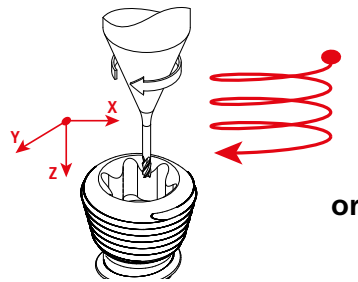

XCZ
Interpolation of linear axes X, Z and subspindle axis C with workpiece on rotation.

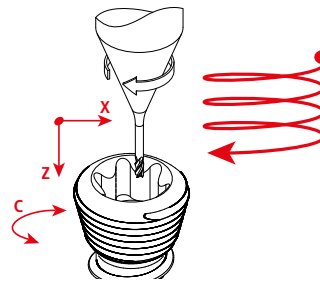

Step 3

Deburring

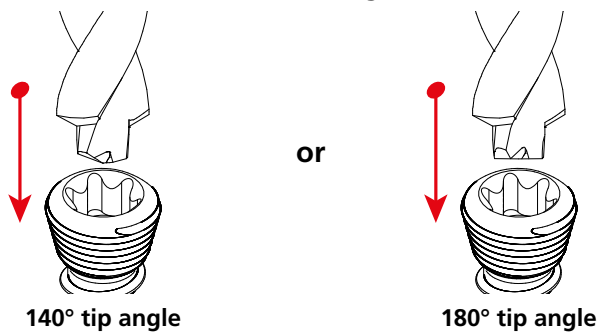

Repeat chamfering to clean the burrs.

Titanium: Helical interpolation is the optimum process, saving up to 20% of cycle time in comparison to side milling process (see page 10).

LOBE DRILLING AND HELICAL INTERPOLATION FOR STAINLESS STEEL AND COBALT CHROME

Step 1

Lobe drilling

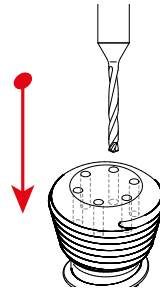

Step 2

Pre-hole drilling with 120° chamfer

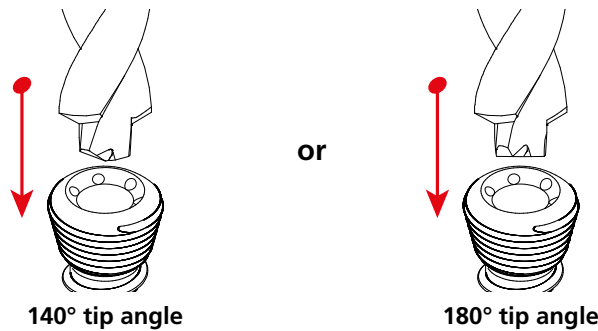

Step 3

**Helical interpolation
XYZ**

**Helical interpolation
XCZ**

XYZ
Interpolation of linear axes X, Y and Z with stationary workpiece.

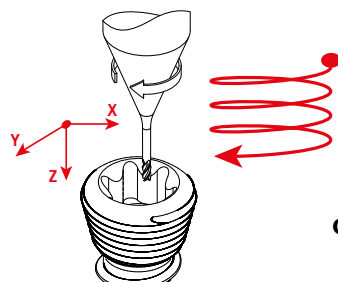

or

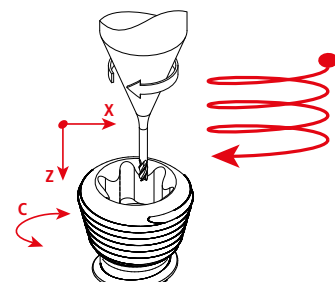

XCZ
Interpolation of linear axes X, Z and subspindle axis C with workpiece on rotation.

Step 4

Deburring

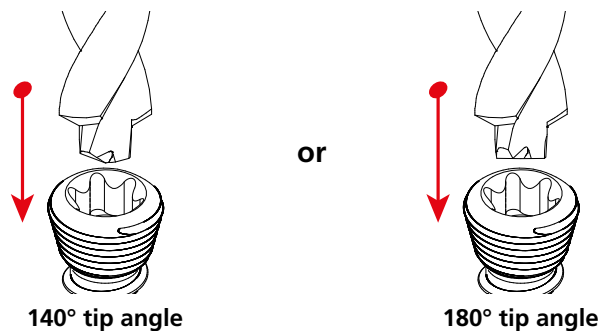

Repeat chamfering to clean the burrs.

Stainless steel: With helical interpolation, drilling of the lobes is required. Result: longer tool life, better dimensional control of the TORX® shape and a more stable process in comparison to side milling process (see page 10).

Cobalt Chrome: Helical interpolation is the optimum process, saving up to 20% of cycle time in comparison to side milling process (see page 11).

NEW

Machining process

SIDE MILLING FOR TITANIUM AND STAINLESS STEEL

Step 1

Pre-hole drilling with 120° chamfer

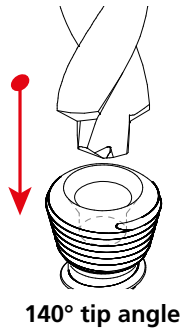

or

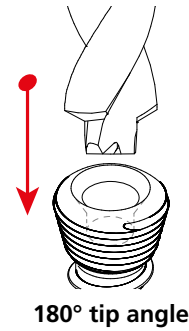

Step 2

Side milling

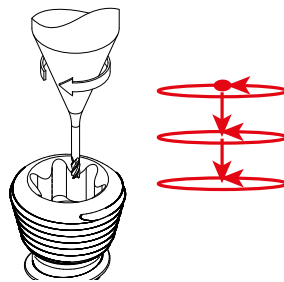

Step 3

Deburring

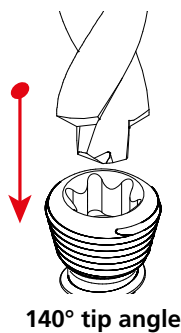

or

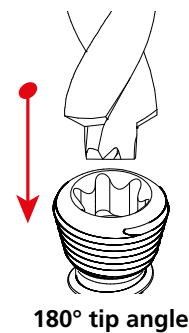

Repeat chamfering to clean the burrs.

Titanium: Helical interpolation is the optimum process (see page 8), saving up to 20% of cycle time in comparison to side milling process.

Stainless steel: With helical interpolation, drilling of the lobes is required (see page 9). Result: longer tool life, better dimensional control of the TORX® shape and a more stable process in comparison to side milling process.

LOBE DRILLING AND SIDE MILLING FOR COBALT CHROME

Step 1

Lobe drilling

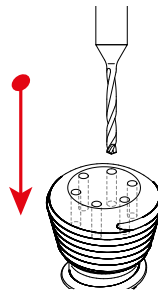

Step 2

Pre-hole drilling with 120° chamfer

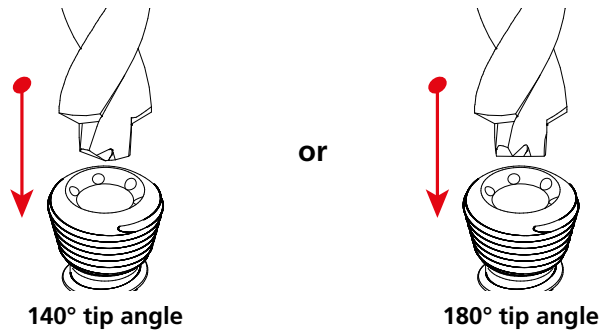

Step 3

Side milling

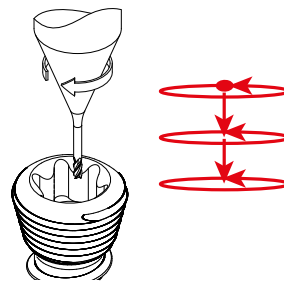

Step 4

Deburring

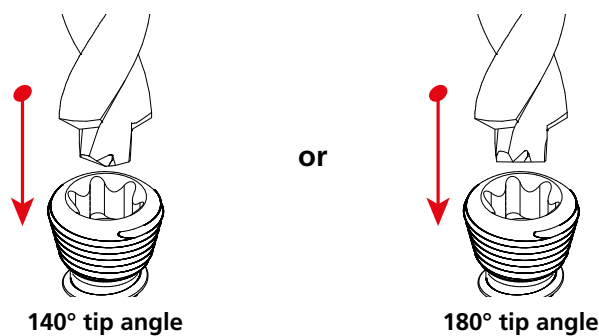

Repeat chamfering to clean the burrs.

Cobalt chrome: Helical interpolation is the optimum process (see page 9), saving up to 20% of cycle time in comparison to side milling process.

CrazyDrill Hexalobe

NEW

Tip 140°

Flat 180°

Ti

SST / CoCr

Ti / SST / CoCr

1 | SHANK

The reinforced solid carbide shank guarantees stability, high degree of concentricity and hence maximum drilling precision.

2 | CARBIDE

The specially developed micro-grain carbide meets all requirements in terms of mechanical properties.

3 | NEW COATING

The high-performance coating eXedur SNP is heat-resistant and super wear-resistant, prevents buildup edges and promotes uniform chip flushing. The result is long tool life.

4 | 120° CHAMFER

The pre-hole and a 120° chamfer are combined on one single operation.

5 | CUTTING GEOMETRY

Two specific geometries have been developed for the machining of:

- Titanium
- Stainless steel / Cobalt chrome

Good chip breaking and quick chip removal are guaranteed.

- Coated
- External cooling

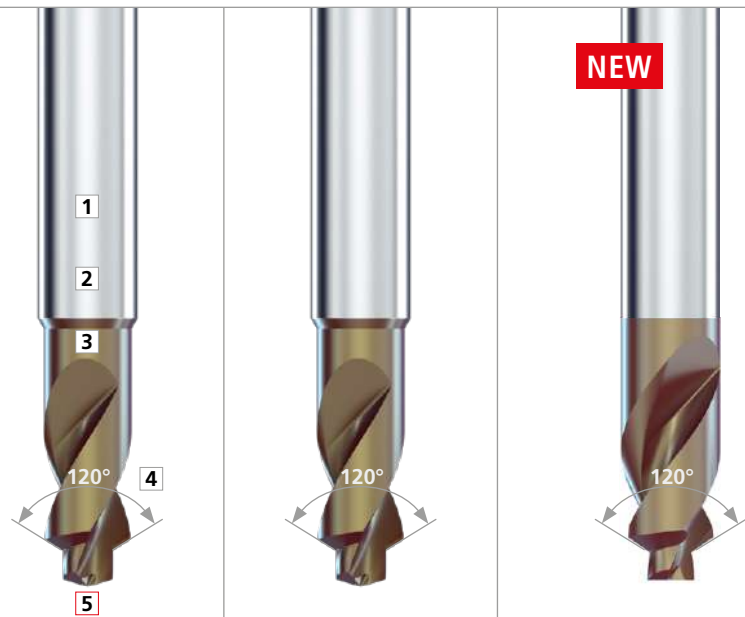

Drill tip

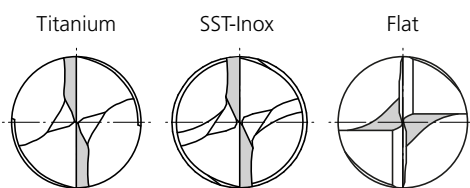

CrazyMill Hexalobe

3.5xd 5xd 3.5xd 5xd 3.5xd 5xd

NEW

Ti

SST-Inox

CoCr

- Coated
- External cooling

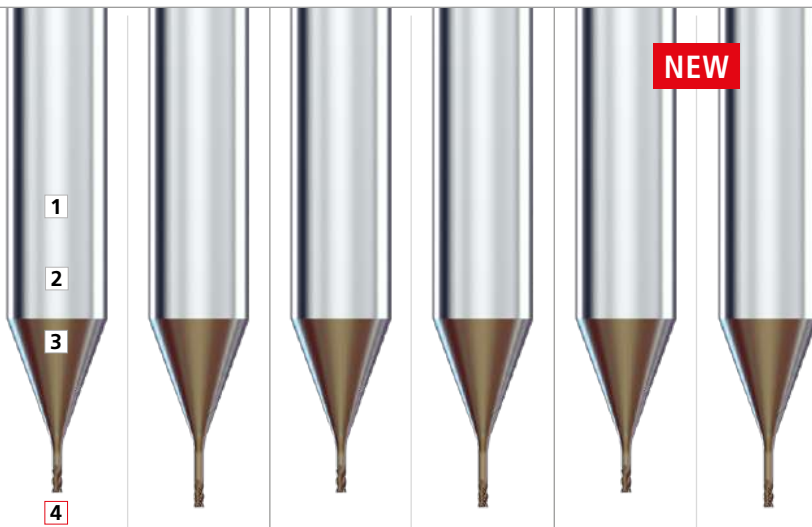

1 | SHANK

The robust carbide shank guarantees stable and vibration free milling. A high degree of precision and excellent surface quality are achieved.

2 | NEW CARBIDE

Due to the high degree of toughness and low thermal conductivity of titanium, stainless steel and cobalt chrom, a specially micro-grain carbide with high stiffness and edge chipping resistance has been developed to perfectly meet all requirements in terms of mechanical properties.

3 | NEW COATING

The high-performance coating eXedur SNP is heat and wear resistant, prevents buildup edges and guarantees optimum chip flushing. The result is a long tool life.

4 | CUTTING GEOMETRY

Three specific geometries have been developed for the machining of:

- **Titanium**
- **Stainless steel**
- **Cobalt chrome**

Vibration free cutting for machining with helical interpolation.

Mill tip form

3 Flutes

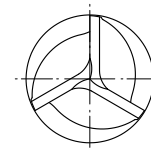

Diameter range
Ø 0.2 - 0.3 mm

4 Flutes

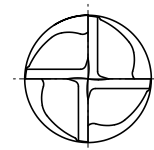

Diameter range
Ø 0.4 - 1.0 mm

CrazyDrill Hexalobe - Tip 140°

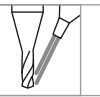
Carbide			Z2		
---------	--	---	----	---	---

Ø d ₁	0.9 - 3.8 mm
Tolerance	0 - 0.008 mm

Dimensions related to ISO 10664

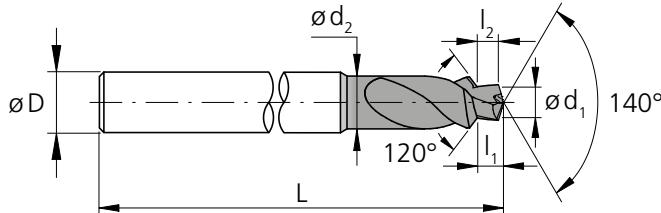

SST	Ti	CoCr
M	S2	S3

TORX® type	d ₁ 0/-0.008 [mm]	l ₁ [mm]	d ₂ [mm]	l ₂ [mm]	D (h6) [mm]	L [mm]	Item number	Titanium	SST-Inox / CoCr	Availability
T4	0.9	0.70	1.7	0.56	3	40	2.CD.006090.120	.T	.J	■
T5	1.0	0.87	2.0	0.72	3	40	2.CD.007100.120	.T	.J	■
T5	1.0	0.75	2.0	0.59	3	40	2.CD.006100.120	.T	.J	■
T6	1.2	1.06	2.2	0.88	3	40	2.CD.007120.120	.T	.J	■
T6	1.2	0.86	2.2	0.67	3	40	2.CD.006120.120	.T	.J	■
T7	1.4	1.05	3.0	0.83	3	40	2.CD.006140.120	.T	.J	■
T7	1.4	1.01	3.0	0.79	3	40	2.CD.005140.120	.T	.J	■
T8	1.6	1.40	3.0	1.15	3	40	2.CD.007160.120	.T	.J	■
T8	1.6	1.05	3.0	0.81	3	40	2.CD.005160.120	.T	.J	■
T10	1.9	1.42	4.0	1.13	4	40	2.CD.005190.120	.T	.J	■
T15	2.3	1.78	4.0	1.42	4	50	2.CD.006230.120	.T	.J	■
T20	2.7	2.12	5.0	1.70	6	50	2.CD.006270.120	.T	.J	■
T25	3.1	2.84	6.0	2.36	6	50	2.CD.007310.120	.T	.J	■
T30	3.8	3.52	6.0	2.93	6	50	2.CD.008380.120	.T	.J	■
T30	3.8	3.04	6.0	2.45	6	50	2.CD.007380.120	.T	.J	■

■ Stock item

Customized combined drill

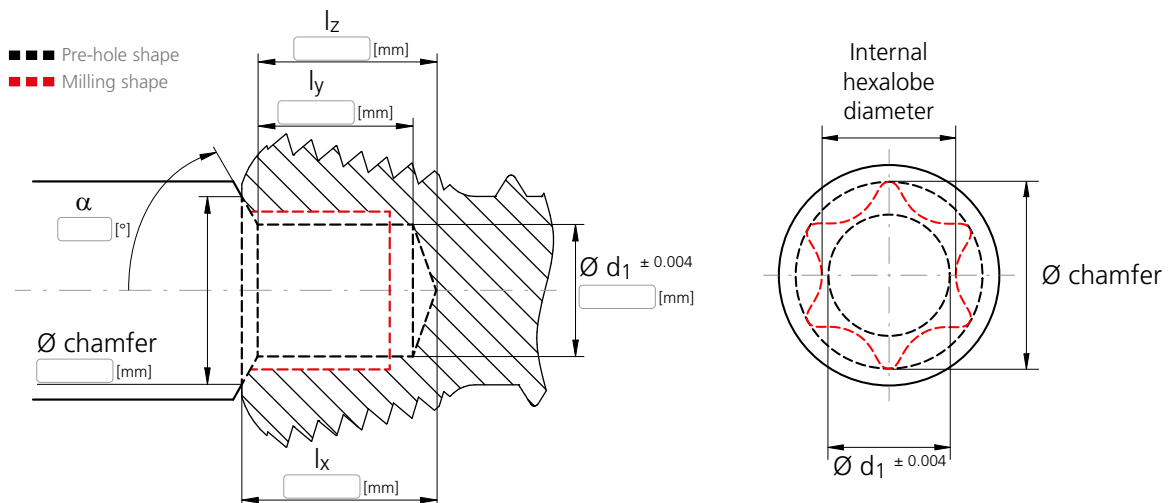

Mikron Tool has an international team of cutting technology experts who are pleased to meet your specific needs and requirements.

You can contact us at mto@mikron.com

CrazyDrill Hexalobe Flat

NEW

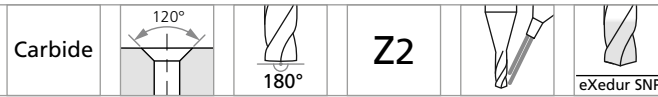

$\varnothing d_1$	0.9 - 3.8 mm
Tolerance	$\begin{matrix} 0 \\ -0.008 \text{ mm} \end{matrix}$

NEW

Dimensions related to ISO 10664

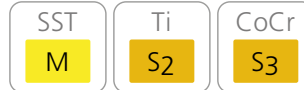
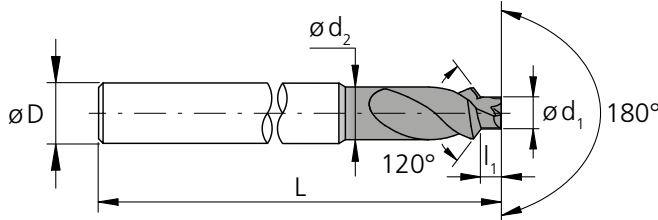

TORX® type	d_1 0/-0.008 [mm]	l_1 [mm]	d_2 [mm]	D (h6) [mm]	L [mm]	Item number	Availability
T4	0.9	0.56	1.7	3	40	2.CDF.006090.120	■
T5	1.0	0.72	2.0	3	40	2.CDF.007100.120	■
T5	1.0	0.59	2.0	3	40	2.CDF.006100.120	■
T6	1.2	0.88	2.2	3	40	2.CDF.007120.120	■
T6	1.2	0.67	2.2	3	40	2.CDF.006120.120	■
T7	1.4	0.83	3.0	3	40	2.CDF.006140.120	■
T7	1.4	0.79	3.0	3	40	2.CDF.005140.120	■
T8	1.6	1.15	3.0	3	40	2.CDF.007160.120	■
T8	1.6	0.81	3.0	3	40	2.CDF.005160.120	■
T10	1.9	1.13	4.0	4	40	2.CDF.005190.120	■
T15	2.3	1.42	4.0	4	50	2.CDF.006230.120	■
T20	2.7	1.70	5.0	6	50	2.CDF.006270.120	■
T25	3.1	2.36	6.0	6	50	2.CDF.007310.120	■
T30	3.8	2.93	6.0	6	50	2.CDF.008380.120	■
T30	3.8	2.45	6.0	6	50	2.CDF.007380.120	■

■ Stock item

Customized combined drill

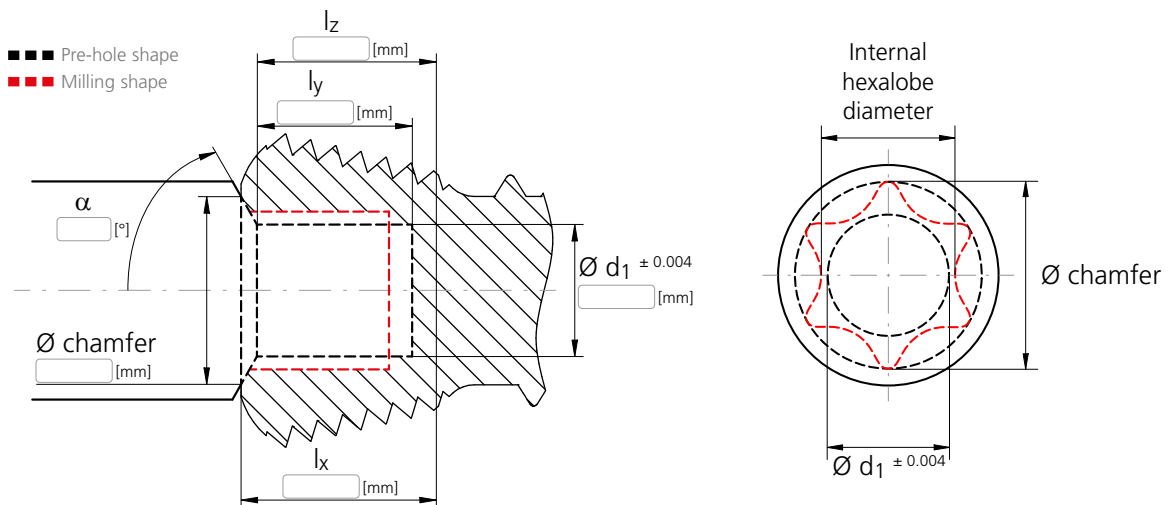

Mikron Tool has an international team of cutting technology experts who are pleased to meet your specific needs and requirements.

You can contact us at mto@mikron.com

NEW

CrazyMill Hexalobe

MILLING WITH EXTERNAL COOLING

Short version



protection
phase of 45°

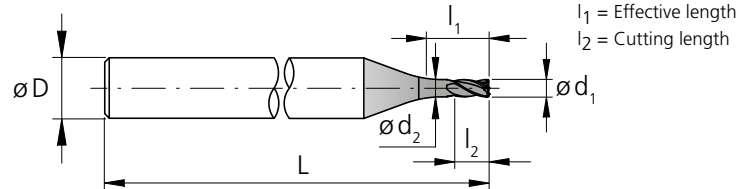

l_1 = Effective length
 l_2 = Cutting length

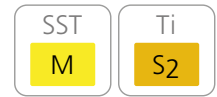

TORX® type	d_1 0/-0.01 [mm]	l_1 [mm]	l_2 [mm]	d_2 [mm]	D (h6) [mm]	L [mm]	Z [Teeth]	Item number Titanium	Item number SST-Inox	Availability
T4	0.20	0.70	0.30	0.19	4	40	3	2.CMT35.B1Z3.020.1	2.CMI35.B1Z3.020.1	■
T5	0.25	0.875	0.40	0.23	4	40	3	2.CMT35.B1Z3.025.1	2.CMI35.B1Z3.025.1	■
T6 / T7	0.30	1.05	0.45	0.28	4	40	3	2.CMT35.B1Z3.030.1	2.CMI35.B1Z3.030.1	■
T8 / T10	0.40	1.40	0.60	0.38	4	40	4	2.CMT35.B1Z4.040.1	2.CMI35.B1Z4.040.1	■
T10 / T15	0.50	1.75	0.75	0.47	4	40	4	2.CMT35.B1Z4.050.1	2.CMI35.B1Z4.050.1	■
T20	0.60	2.10	0.90	0.56	4	40	4	2.CMT35.B1Z4.060.1	2.CMI35.B1Z4.060.1	■
T25	0.80	2.80	1.20	0.75	4	40	4	2.CMT35.B1Z4.080.1	2.CMI35.B1Z4.080.1	■
T30	1.00	3.50	1.50	0.94	4	40	4	2.CMT35.B1Z4.100.1	2.CMI35.B1Z4.100.1	■

■ Stock item

NEW Short version



protection
phase of 45°

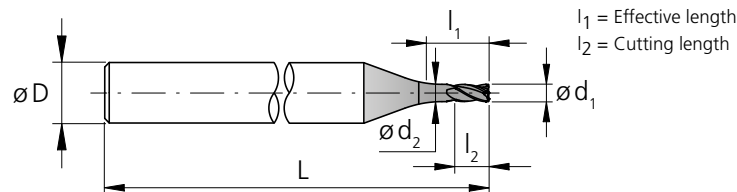



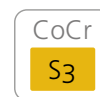

l_1 = Effective length
 l_2 = Cutting length



TORX® type	d_1 0/-0.01 [mm]	l_1 [mm]	l_2 [mm]	d_2 [mm]	D (h6) [mm]	L [mm]	Z [Teeth]	Item number Cobalt - Chrome	Availability
T4	0.20	0.70	0.30	0.19	4	40	3	2.CMR35.B1Z3.020.1	■
T5	0.25	0.875	0.40	0.23	4	40	3	2.CMR35.B1Z3.025.1	■
T6 / T7	0.30	1.05	0.45	0.28	4	40	3	2.CMR35.B1Z3.030.1	■
T8 / T10	0.40	1.40	0.60	0.38	4	40	4	2.CMR35.B1Z4.040.1	■
T10 / T15	0.50	1.75	0.75	0.47	4	40	4	2.CMR35.B1Z4.050.1	■
T20	0.60	2.10	0.90	0.56	4	40	4	2.CMR35.B1Z4.060.1	■
T25	0.80	2.80	1.20	0.75	4	40	4	2.CMR35.B1Z4.080.1	■
T30	1.00	3.50	1.50	0.94	4	40	4	2.CMR35.B1Z4.100.1	■

■ Stock item

Carbide	Z 3-4					NEW	
					$\varnothing d_1$		0.2 - 1.0 mm
					Tolerance		0 - 0.01 mm

Long version

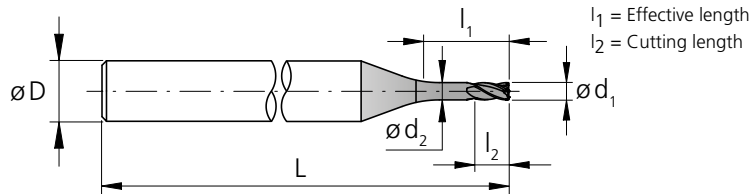
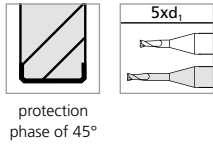

TORX® type	d_1 0/-0.01 [mm]	l_1 [mm]	l_2 [mm]	d_2 [mm]	D (h6) [mm]	L [mm]	Z [Teeth]	Item number Titanium	Item number SST-Inox	Availability
T4	0.20	1.00	0.30	0.19	4	40	3	2.CMT35.C1Z3.020.1	2.CMI35.C1Z3.020.1	■
T5	0.25	1.25	0.40	0.23	4	40	3	2.CMT35.C1Z3.025.1	2.CMI35.C1Z3.025.1	■
T6 / T7	0.30	1.50	0.45	0.28	4	40	3	2.CMT35.C1Z3.030.1	2.CMI35.C1Z3.030.1	■
T8 / T10	0.40	2.00	0.60	0.38	4	40	4	2.CMT35.C1Z4.040.1	2.CMI35.C1Z4.040.1	■
T10 / T15	0.50	2.50	0.75	0.47	4	40	4	2.CMT35.C1Z4.050.1	2.CMI35.C1Z4.050.1	■
T20	0.60	3.00	0.90	0.56	4	40	4	2.CMT35.C1Z4.060.1	2.CMI35.C1Z4.060.1	■
T25	0.80	4.00	1.20	0.75	4	40	4	2.CMT35.C1Z4.080.1	2.CMI35.C1Z4.080.1	■
T30	1.00	5.00	1.50	0.94	4	40	4	2.CMT35.C1Z4.100.1	2.CMI35.C1Z4.100.1	■

■ Stock item

NEW Long version

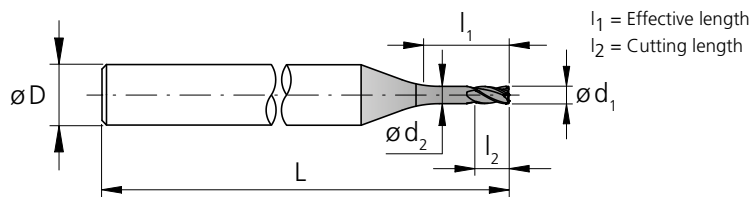
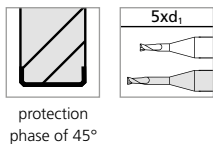

TORX® type	d_1 0/-0.01 [mm]	l_1 [mm]	l_2 [mm]	d_2 [mm]	D (h6) [mm]	L [mm]	Z [Teeth]	Item number Cobalt - Chrome	Availability
T4	0.20	1.00	0.30	0.19	4	40	3	2.CMR35.C1Z3.020.1	■
T5	0.25	1.25	0.40	0.23	4	40	3	2.CMR35.C1Z3.025.1	■
T6 / T7	0.30	1.50	0.45	0.28	4	40	3	2.CMR35.C1Z3.030.1	■
T8 / T10	0.40	2.00	0.60	0.38	4	40	4	2.CMR35.C1Z4.040.1	■
T10 / T15	0.50	2.50	0.75	0.47	4	40	4	2.CMR35.C1Z4.050.1	■
T20	0.60	3.00	0.90	0.56	4	40	4	2.CMR35.C1Z4.060.1	■
T25	0.80	4.00	1.20	0.75	4	40	4	2.CMR35.C1Z4.080.1	■
T30	1.00	5.00	1.50	0.94	4	40	4	2.CMR35.C1Z4.100.1	■

■ Stock item

CrazyDrill SST-Inox - Type IK / IN

Carbide



Z2



$\varnothing d_1$ 0.1 - 3.0 mm
Tolerance + 0.004 mm
0

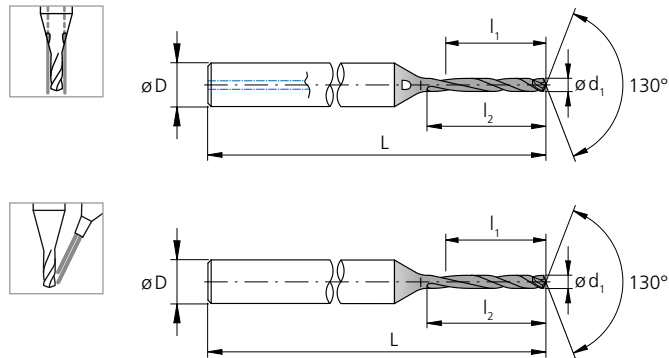

TORX® type	d_1 [mm]	l_1 [mm]	l_2 [mm]	D (h6) [mm]	L [mm]	Item number Integrated cooling	Item number External cooling	Availability
T4 - T5	0.25	2.0	2.5	3	38	2.CD.080025.IK	2.CD.080025.IN	■
T6	0.30	2.4	2.9	3	38	2.CD.080030.IK	2.CD.080030.IN	■
T7	0.35	2.8	3.4	3	38	2.CD.080035.IK	2.CD.080035.IN	■
T8	0.40	3.2	3.9	3	38	2.CD.080040.IK	2.CD.080040.IN	■
T10	0.50	4.0	4.9	3	42	2.CD.080050.IK	2.CD.080050.IN	■
T15	0.60	4.8	5.9	3	42	2.CD.080060.IK	2.CD.080060.IN	■
T20	0.70	5.6	6.9	3	45	2.CD.080070.IK	2.CD.080070.IN	■
T25	0.80	6.4	7.8	3	45	2.CD.080080.IK	2.CD.080080.IN	■
T30	1.00	8.0	9.8	3	48	2.CD.080100.IK	2.CD.080100.IN	■

■ Stock item

Cutting tool recommendation

Only for process with lobe drilling in stainless steel or chrome cobalt

TORX® type	d _{Lobe} [mm]	Stock removal [mm]	Lobe drilling		Pre-hole drilling	Socket milling	
			Integrated cooling	External cooling		Stainless steel	Chrome cobalt
T4	0.25	0.02	2.CD.080025.IK	2.CD.080025.IN	2.CD.006090.120.I	2.CMI35.B1Z3.020.1 2.CMI35.C1Z3.020.1	2.CMR35.B1Z3.020.1 2.CMR35.C1Z3.020.1
T5	0.25	0.05	2.CD.080025.IK	2.CD.080025.IN	2.CD.007100.120.I	2.CMI35.B1Z3.020.1 2.CMI35.C1Z3.020.1	2.CMR35.B1Z3.020.1 2.CMR35.C1Z3.020.1
T5	0.25	0.05	2.CD.080025.IK	2.CD.080025.IN	2.CD.006100.120.I	2.CMI35.B1Z3.020.1 2.CMI35.C1Z3.020.1	2.CMR35.B1Z3.020.1 2.CMR35.C1Z3.020.1
T6	0.30	0.05	2.CD.080030.IK	2.CD.080030.IN	2.CD.007120.120.I	2.CMI35.B1Z3.030.1 2.CMI35.C1Z3.030.1	2.CMR35.B1Z3.030.1 2.CMR35.C1Z3.030.1
T6	0.30	0.05	2.CD.080030.IK	2.CD.080030.IN	2.CD.006120.120.I	2.CMI35.B1Z3.030.1 2.CMI35.C1Z3.030.1	2.CMR35.B1Z3.030.1 2.CMR35.C1Z3.030.1
T7	0.35	0.07	2.CD.080035.IK	2.CD.080035.IN	2.CD.006140.120.I	2.CMI35.B1Z3.030.1 2.CMI35.C1Z3.030.1	2.CMR35.B1Z3.030.1 2.CMR35.C1Z3.030.1
T7	0.35	0.07	2.CD.080035.IK	2.CD.080035.IN	2.CD.005140.120.I	2.CMI35.B1Z3.030.1 2.CMI35.C1Z3.030.1	2.CMR35.B1Z3.030.1 2.CMR35.C1Z3.030.1
T8	0.40	0.08	2.CD.080040.IK	2.CD.080040.IN	2.CD.007160.120.I	2.CMI35.B1Z4.040.1 2.CMI35.C1Z4.040.1	2.CMR35.B1Z4.040.1 2.CMR35.C1Z4.040.1
T8	0.40	0.08	2.CD.080040.IK	2.CD.080040.IN	2.CD.005160.120.I	2.CMI35.B1Z4.040.1 2.CMI35.C1Z4.040.1	2.CMR35.B1Z4.040.1 2.CMR35.C1Z4.040.1
T10	0.50	0.06	2.CD.080050.IK	2.CD.080050.IN	2.CD.005190.120.I	2.CMI35.B1Z4.040.1 2.CMI35.C1Z4.040.1 2.CMI35.B1Z4.050.1 2.CMI35.C1Z4.050.1	2.CMR35.B1Z4.040.1 2.CMR35.C1Z4.040.1 2.CMR35.B1Z4.050.1 2.CMR35.C1Z4.050.1
T15	0.60	0.07	2.CD.080060.IK	2.CD.080060.IN	2.CD.006230.120.I	2.CMI35.B1Z4.050.1 2.CMI35.C1Z4.050.1	2.CMR35.B1Z4.050.1 2.CMR35.C1Z4.050.1
T20	0.70	0.09	2.CD.080070.IK	2.CD.080070.IN	2.CD.006270.120.I	2.CMI35.B1Z4.060.1 2.CMI35.C1Z4.060.1	2.CMR35.B1Z4.060.1 2.CMR35.C1Z4.060.1
T25	0.80	0.10	2.CD.080080.IK	2.CD.080080.IN	2.CD.007310.120.I	2.CMI35.B1Z4.080.1 2.CMI35.C1Z4.080.1	2.CMR35.B1Z4.080.1 2.CMR35.C1Z4.080.1
T30	1.00	0.12	2.CD.080100.IK	2.CD.080100.IN	2.CD.008380.120.I	2.CMI35.B1Z4.100.1 2.CMI35.C1Z4.100.1	2.CMR35.B1Z4.100.1 2.CMR35.C1Z4.100.1
T30	1.00	0.12	2.CD.080100.IK	2.CD.080100.IN	2.CD.007380.120.I	2.CMI35.B1Z4.100.1 2.CMI35.C1Z4.100.1	2.CMR35.B1Z4.100.1 2.CMR35.C1Z4.100.1

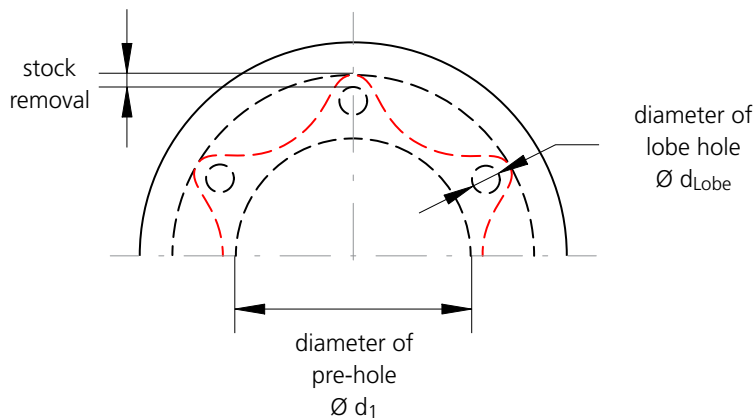

Lobe drilling

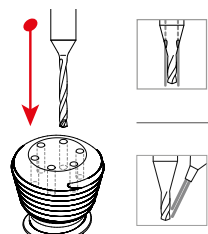

Materials group	Material	Mat. no.	DIN	AISI/ASTM/UNS	v_c [m/min]	Q_1	Q_x
M	Stainless steel austenitic	1.4435	X2CrNiMo 18-14-3	AISI 316L	30 – 45	1 - 4xd1	1 - 2xd1
		1.4441	X2CrNiMo 18-15-3	AISI 316LM			
S ₃	CrCo alloys	2.4964	CoCr20W15Ni	Haynes 25	40 – 50	1 - 3xd1	1 - 2xd1
			CrCoMo28	ASTM F1537			
M	Stainless steel austenitic	1.4435	X2CrNiMo 18-14-3	AISI 316L	25 – 30	0.5 - 1xd1	0.5xd1
		1.4441	X2CrNiMo 18-15-3	AISI 316LM			
S ₃	CrCo alloys	2.4964	CoCr20W15Ni	Haynes 25	25 – 35	0.5 - 1xd1	0.5xd1
			CrCoMo28	ASTM F1537			

Pre-hole drilling



Materials group	Material	Mat. no.	DIN	AISI/ASTM/UNS	v_c [m/min]
M	Stainless steel austenitic	1.4435	X2CrNiMo 18-14-3	AISI 316L	25 – 35
		1.4441	X2CrNiMo 18-15-3	AISI 316LM	
S ₂	Titanium alloys	3.7165	TiAl6V4	ASTM B348 / F136	20 – 30
		9.9367	TiAl6Nb7	ASTM F1295	
S ₃	CrCo alloys	2.4964	CoCr20W15Ni	Haynes 25	25 – 35
			CrCoMo28	ASTM F1537	

Helical interpolation (XYZ / X CZ) - 3.5 x d / 5 x d



Materials group	Material	Mat. no.	DIN	AISI/ASTM/UNS	p (pitch)	
					3.5 x d1	5 x d1
M	Stainless steel austenitic	1.4435	X2CrNiMo 18-14-3	AISI 316L	0.2 - 0.8 x d1	0.1 - 0.4 x d1
		1.4441	X2CrNiMo 18-15-3	AISI 316LM		
S ₂	Titanium alloys	3.7165	TiAl6V4	ASTM B348 / F136	0.2 - 0.8 x d1	0.1 - 0.4 x d1
		9.9367	TiAl6Nb7	ASTM F1295		
S ₃	CrCo alloys	2.4964	CoCr20W15Ni	Haynes 25	0.2 - 0.8 x d1	0.1 - 0.4 x d1
			CrCoMo28	ASTM F1537		

Note: In case of $p = 0.8 \times d1$ decrease the feed f_z by 30% to increase tool life and profile precision.

Side milling - 3.5 x d / 5 x d

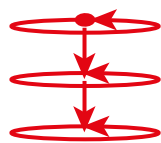

Materials group	Material	Mat. no.	DIN	AISI/ASTM/UNS	$a_{p, max}$	a_e
M	Stainless steel austenitic	1.4435	X2CrNiMo 18-14-3	AISI 316L	0.5 x d1	0.1 x d1
		1.4441	X2CrNiMo 18-15-3	AISI 316LM		
S ₂	Titanium alloys	3.7165	TiAl6V4	ASTM B348 / F136	0.5 x d1	variable
		9.9367	TiAl6Nb7	ASTM F1295		
S ₃	CrCo alloys	2.4964	CoCr20W15Ni	Haynes 25	0.5 x d1	0.1 x d1
			CrCoMo28	ASTM F1537		

General advise: Cutting conditions have been tested and approved with $n = 30'000 - 40'000$ rpm, different cutting speeds may affect tool life.

v_c [m/min]
 f [mm/rev]

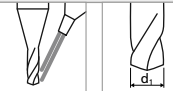

	T4 Ød1 0.25mm f	T5 Ød1 0.30mm f	T6 Ød1 0.30mm f	T7 Ød1 0.30mm f	T8 Ød1 0.40mm f	T10 Ød1 0.50mm f	T15 Ød1 0.60mm f	T20 Ød1 0.70mm f	T25 Ød1 0.80mm f	T30 Ød1 1.00mm f
	0.01 - 0.02	0.01 - 0.02	0.01 - 0.02	0.01 - 0.02	0.01 - 0.02	0.01 - 0.02	0.015 - 0.025	0.015 - 0.025	0.015 - 0.025	0.025 - 0.035
	0.02 - 0.03	0.02 - 0.03	0.02 - 0.03	0.02 - 0.03	0.02 - 0.03	0.02 - 0.03	0.015 - 0.020	0.015 - 0.020	0.015 - 0.020	0.05 - 0.06
	0.010 - 0.015	0.010 - 0.015	0.010 - 0.015	0.010 - 0.015	0.010 - 0.015	0.010 - 0.015	0.015 - 0.020	0.015 - 0.020	0.015 - 0.020	0.02 - 0.03
	0.015 - 0.025	0.015 - 0.025	0.015 - 0.025	0.015 - 0.025	0.015 - 0.025	0.015 - 0.025	0.025 - 0.035	0.025 - 0.035	0.025 - 0.035	0.04 - 0.05

v_c [m/min]
 f [mm/rev]

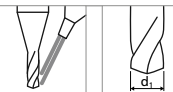

	T4 Ød1 0.9mm f	T5 Ød1 1.0mm f	T6 Ød1 1.2mm f	T7 Ød1 1.4mm f	T8 Ød1 1.6mm f	T10 Ød1 1.9mm f	T15 Ød1 2.3mm f	T20 Ød1 2.7mm f	T25 Ød1 3.1mm f	T30 Ød1 3.8mm f
	0.02 - 0.03	0.02 - 0.03	0.03 - 0.04	0.03 - 0.04	0.03 - 0.04	0.05 - 0.06	0.05 - 0.06	0.06 - 0.07	0.07 - 0.08	0.07 - 0.08
	0.010 - 0.015	0.010 - 0.015	0.012 - 0.018	0.014 - 0.020	0.015 - 0.025	0.020 - 0.030	0.025 - 0.035	0.025 - 0.040	0.030 - 0.045	0.045 - 0.070
	0.005 - 0.015	0.005 - 0.015	0.006 - 0.018	0.007 - 0.020	0.008 - 0.025	0.010 - 0.030	0.012 - 0.035	0.015 - 0.040	0.015 - 0.050	0.020 - 0.055

v_c [m/min]
 f_z [mm]
 p [mm]

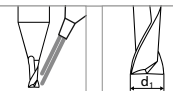

	T4 Ød1 0.20mm v_c f_z		T5 Ød1 0.25mm v_c f_z		T6 - T7 Ød1 0.30mm v_c f_z		T8 - T10 Ød1 0.40mm v_c f_z		T10 - T15 Ød1 0.50mm v_c f_z		T20 Ød1 0.60mm v_c f_z		T25 Ød1 0.80mm v_c f_z		T30 Ød1 1.00mm v_c f_z	
	20 - 40	0.0010	25 - 50	0.0010	30 - 60	0.0010	40 - 75	0.0015	50 - 90	0.0020	60 - 100	0.0025	70 - 130	0.0030	80 - 140	0.0040
	20 - 40	0.0010	25 - 50	0.0010	30 - 60	0.0010	40 - 75	0.0015	50 - 90	0.0020	60 - 100	0.0025	70 - 130	0.0030	80 - 140	0.0040
	20 - 40	0.0008	25 - 50	0.0008	30 - 60	0.0008	40 - 75	0.0012	50 - 90	0.0015	60 - 100	0.0020	70 - 130	0.0025	80 - 140	0.0030

v_c [m/min] a_p [mm]
 f_z [mm] a_e [mm]

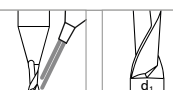

	T4 Ød1 0.20mm v_c f_z		T5 Ød1 0.25mm v_c f_z		T6 - T7 Ød1 0.30mm v_c f_z		T8 - T10 Ød1 0.40mm v_c f_z		T10 - T15 Ød1 0.50mm v_c f_z		T20 Ød1 0.60mm v_c f_z		T25 Ød1 0.80mm v_c f_z		T30 Ød1 1.00mm v_c f_z	
	20 - 40	0.0015	25 - 50	0.0025	30 - 60	0.0030	40 - 75	0.0045	50 - 90	0.0060	60 - 100	0.0065	70 - 130	0.0080	80 - 140	0.0100
	20 - 40	0.0015	25 - 50	0.0025	30 - 60	0.0030	40 - 75	0.0045	50 - 90	0.0060	60 - 100	0.0065	70 - 130	0.0080	80 - 140	0.0100
	20 - 40	0.0012	25 - 50	0.0020	30 - 60	0.0025	40 - 75	0.0035	50 - 90	0.0045	60 - 100	0.0050	70 - 130	0.0060	80 - 140	0.0075





Headquarter and Production

MIKRON SWITZERLAND AG, AGNO

Division Tool

Via Campagna 1

6982 Agno

Switzerland

Phone +41 91 610 40 00

Fax. +41 91 610 40 10

mto@mikron.com

Production and Regrinding

MIKRON GERMANY GMBH

Abteilung Werkzeuge

Berner Feld 71

78628 Rottweil

Germany

Phone +49 741 5380 450

Fax. +49 741 5380 480

info.mtr@mikron.com

North and South America Sales

MIKRON CORP. MONROE

200 Main Street

Monroe, CT 06468

USA

Phone +1 203 261 3100

Fax. +1 203 268 4752

mmo@mikron.com

China Sales

MIKRON TOOL (SHANGHAI) CO., LTD.

Room A209, Building 3,

No. 526, 3rd East Fu te Road,

Shanghai, 200131

P. R. China

Phone +86 21 2076 5671

Fax. +86 21 2076 5562

mtc@mikron.com

地址: 中国 (上海) 自由贸易试验区

中国上海市富特东三路526号3号楼第二层

A209室

邮编: 200131

Website



Youtube



LinkedIn



www.mikrontool.com

Information and technical data are liable to changes without prior notification.

Mikron® is a trademark of Mikron Holding AG, Biel (Switzerland).

TORX® is a trademark of Camcar Innovations, Fenton (USA).



2.MKTG.00592 - 04.2024 - EU - EN